

# Panasonic®

## Portable Stereo CD System

# RX-DS11

## Operating Instructions

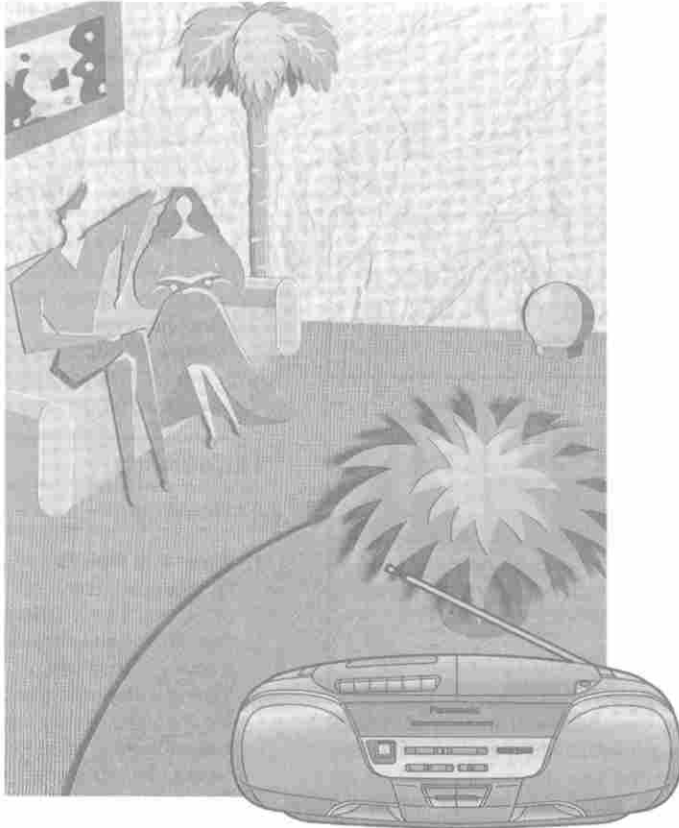

The model number and serial number of this product can be found on either the back or the bottom of the unit.

Please note them in the space provided below and keep for future reference.

MODEL NUMBER           RX-DS11          

SERIAL NUMBER                                   

Before connecting, operating or adjusting this product, please read these instructions completely. Please save this manual.

COMPACT  
disc  
DIGITAL AUDIO

# Dear customer

Thank you for purchasing this product.  
For optimum performance and safety, please read these instructions carefully.

## Table of Contents

Precautions .....	2
Listening Caution .....	3
Location of Controls .....	4
Power Sources .....	5
Common Operations .....	5
Listening to CDs .....	6
Listening to Tapes .....	7
Listening to the Radio .....	8
Recording Radio Programs .....	8
Recording Compact Discs .....	9
Troubleshooting Guide .....	10
Concerning Compact Discs .....	11
Concerning Cassette Tapes .....	11
Maintenance .....	Back cover
Technical Specifications .....	Back cover
Product Service .....	Back cover

**CAUTION:**  
TO PREVENT ELECTRIC SHOCK  
MATCH WIDE BLADE OF PLUG TO  
WIDE SLOT, FULLY INSERT.



**CAUTION**  
RISK OF ELECTRIC SHOCK  
DO NOT OPEN

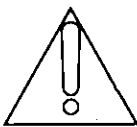

**CAUTION:** TO REDUCE THE RISK OF ELECTRIC SHOCK, DO NOT REMOVE SCREWS. NO USER-SERVICEABLE PARTS INSIDE. REFER SERVICING TO QUALIFIED SERVICE PERSONNEL.



The lightning flash with arrowhead symbol, within an equilateral triangle, is intended to alert the user to the presence of un-insulated "dangerous voltage" within the product's enclosure that may be of sufficient magnitude to constitute a risk of electric shock to persons.

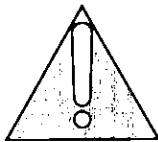

The exclamation point within an equilateral triangle is intended to alert the user to the presence of important operating and maintenance (servicing) instructions in the literature accompanying the appliance.

**CAUTION!**  
THIS PRODUCT UTILIZES A LASER.  
USE OF CONTROLS OR ADJUSTMENTS OR  
PERFORMANCE OF PROCEDURES OTHER  
THAN THOSE SPECIFIED HEREIN MAY  
RESULT IN HAZARDOUS RADIATION EX-  
POSURE.  
DO NOT OPEN COVERS AND DO NOT  
REPAIR YOURSELF. REFER SERVICING  
TO QUALIFIED PERSONNEL.

## Precautions

Before using this unit please read these operating instructions carefully. Take special care to follow the warnings indicated on the unit itself as well as the safety suggestions listed below.

Afterwards keep them handy for future reference.

## Safety

- 1. Power Source**—The unit should be connected to power supply only of the type described in the operating instructions or as marked on the unit.
- 2. Polarization**—If the unit is equipped with a polarized AC power plug (a plug having one blade wider than the other), that plug will fit into the AC outlet only one way. This is a safety feature. If you are unable to insert the plug fully into the outlet, try reversing the plug. If the plug should still fail to fit, contact your electrician to replace your obsolete outlet. Do not defeat the safety purpose of the polarized plug.
- 3. Power Cord Protection**—AC power supply cords should be routed so that they are not likely to be walked on or pinched by items placed upon or against them. Never take hold of the plug or cord if your hand is wet, and always grasp the plug body when connecting or disconnecting it.
- 4. Nonuse Periods**—When the unit is not used, turn the power off. When left unused for a long period of time, the unit should be unplugged from the household AC outlet.

## Installation

### Environment

- 1. Water and Moisture**—Do not use this unit near water—for example, near a bathtub, washbowl, swimming pool, or the like. Damp basements should also be avoided.
- 2. Condensation**—Moisture may form on the lens in the following conditions...
  - immediately after a heater has been turned on.
  - in a steamy or very humid room.
  - when the unit is suddenly moved from a cold environment to a warm one.If moisture forms inside this unit, it may not operate properly. To correct this problem, turn on the power and wait about one hour for the moisture to evaporate.
- 3. Heat**—The unit should be situated away from heat sources such as radiators and the like. It also should not be placed in temperatures less than 5°C (41°F) or greater than 35°C (95°F).

### Placement

- 1. Ventilation**—The unit should be situated so that its location or position does not interfere with its proper ventilation. Allow 10 cm (4") clearance from the rear of the unit.
- 2. Foreign Material**—Care should be taken so that objects do not fall into and liquids are not spilled into the unit. Do not subject this unit to excessive smoke, dust, mechanical vibration, or shock.
- 3. Magnetism**—The unit should be situated away from equipment or devices that generate strong magnetic fields.
- 4. Stacking**—Do not place heavy objects, other than system components, on top of the unit.

## Listening caution

5. **Surface**—Place the unit on a flat, level surface.
6. **Carts and Stands**—The unit should be used only with a cart or stand that is recommended by the manufacturer. The unit and cart combination should be moved with care. Quick stops, excessive force, and uneven surfaces may cause the unit and cart combination to overturn. 
7. **Wall or Ceiling Mounting**—The unit should not be mounted to a wall or ceiling, unless specified in this operating instructions.

## Maintenance

Clean the cabinet, panel and controls with a soft cloth lightly moistened with mild detergent solution.

Do not use any type of abrasive pad, scouring powder or solvent such as alcohol or benzene.

## Service

1. **Damage Requiring Service**—The unit should be serviced by qualified service personnel when:
  - (a) The AC power supply cord or the plug has been damaged; or
  - (b) Objects have fallen or liquid has been spilled into the unit; or
  - (c) The unit has been exposed to rain; or
  - (d) The unit does not appear to operate normally or exhibits a marked change in performance; or
  - (e) The unit has been dropped, or the enclosure damaged.
2. **Servicing**—The user should not attempt to service the unit beyond that described in the operating instructions. All other servicing should be referred to an authorized service personnel.  
(Only for U.S.A.)  
Call 1-800-545-2672 for the address of an authorized factory servicenter.



Selecting fine audio equipment such as the unit you've just purchased is only the start of your musical enjoyment. Now it's time to consider how you can maximize the fun and excitement your equipment offers. This manufacturer and the Electronic Industries Association's Consumer Electronics Group want you to get the most out of your equipment by playing it at a safe level. One that lets the sound come through loud and clear without annoying blaring or distortion—and, most importantly, without affecting your sensitive hearing.

We recommend you to avoid prolonged exposure to excessive noise.

Sound can be deceiving. Over time your hearing "comfort level" adapts to higher volumes of sound. So what sounds "normal" can actually be loud and harmful to your hearing. Guard against this by setting your equipment at a safe level BEFORE your hearing adapts.

To establish a safe level:

- Start your volume control at a low setting.
- Slowly increase the sound until you can hear it comfortably and clearly, and without distortion.

Once you have established a comfortable sound level:

- Set the dial and leave it there.

Taking a minute to do this now will help to prevent hearing damage or loss in the future. After all, we want you listening for a lifetime.

**WARNING:**  
**TO REDUCE THE RISK OF FIRE, ELECTRIC SHOCK OR PRODUCT DAMAGE, DO NOT EXPOSE THIS APPLIANCE TO RAIN, SPLASHING, DRIPPING OR MOISTURE.**

## THE FOLLOWING PHRASES ARE APPLIED ONLY FOR U.S.A.:

### CAUTION:

This equipment has been tested and found to comply with the limits for a Class B digital device, pursuant to Part 15 of the FCC Rules.

These limits are designed to provide reasonable protection against harmful interference in a residential installation. This equipment generates, uses and can radiate radio frequency energy and, if not installed and used in accordance with the instructions, may cause harmful interference to radio communications. However, there is no guarantee that interference will not occur in a particular installation. If this equipment does cause harmful interference to radio or television reception, which can be determined by turning the equipment off and on, the user is encouraged to try to correct the interference by one of the following measures:

- Reorient or relocate the receiving antenna.
- Increase the separation between the equipment and receiver.

- Connect the equipment into an outlet on a circuit different from that to which the receiver is connected.
- Consult the dealer or an experienced radio/TV technician for help.

FCC Notice: This system complies with new Part 15, except for the radio receiver, which complies with old Part 15, Subpart C of the FCC Rules. Operation is subject to the following two conditions: (1) This device may not cause harmful interference, and (2) this device must accept any interference received, including interference that may cause undesirable operation. The radio receiver is not subject to above item (2).

Any unauthorized changes or modifications to this equipment would void the user's authority to operate this device.

# Location of Controls

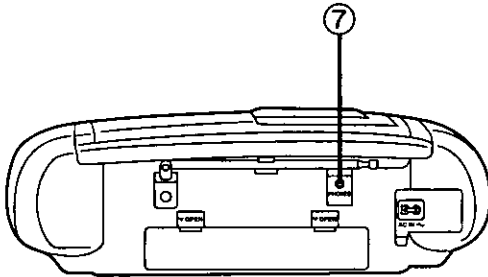
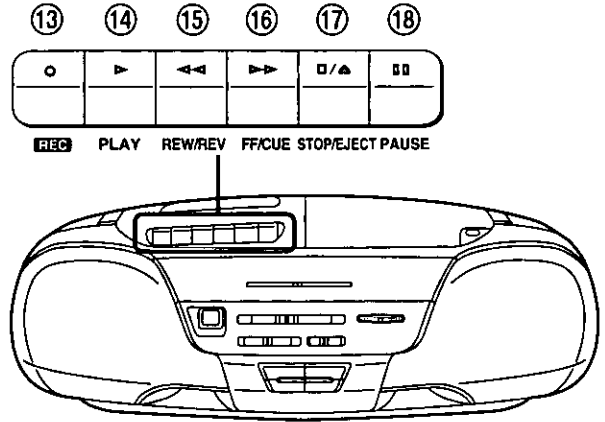
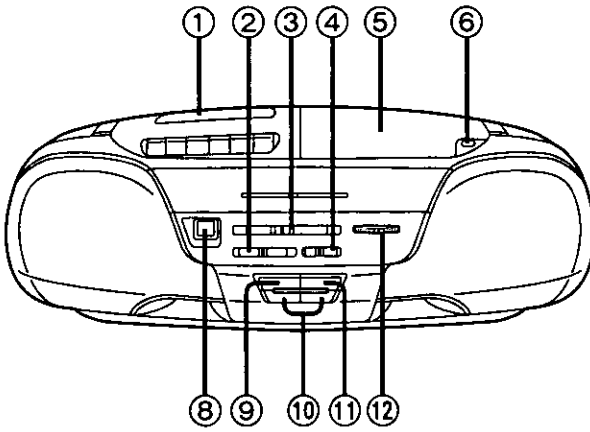

No.	Name	Ref. page
-----	------	-----------

## Basic controls

①	Cassette lid	7
②	Function selector/operation switch (SELECTOR)	6-9
③	Volume control (VOLUME)	5
④	XBS switch (XBS)	5
⑤	Disc lid	6
⑥	Disc lid open button ( $\Delta$ CD)	6
⑦	Headphones jack (PHONES)	5

## CD controls

⑧	Display panel	6
⑨	Stop button ( $\square$ CD)	6
⑩	Skip/search buttons ( $\lll$ , $\ggg$ )	6
⑪	Play/pause button (CD $\triangleright \parallel$ )	6

No.	Name	Ref. page
-----	------	-----------

## Tuner controls

⑫	Tuning dial (TUNING)	8
---	----------------------	---

## Cassette deck controls

⑬	Recording button ( $\circ$ REC)	8, 9
⑭	Playback button ( $\triangleright$ PLAY)	7
⑮	Rewind/review button ( $\lll$ REW/REV)	7
⑯	Fast forward/cue button ( $\ggg$ FF/CUE)	7
⑰	Stop/eject button ( $\square/\Delta$ STOP/EJECT)	7-9
⑱	Pause button ( $\parallel$ PAUSE)	7

# Power Sources

# Common Operations

## Using household AC power

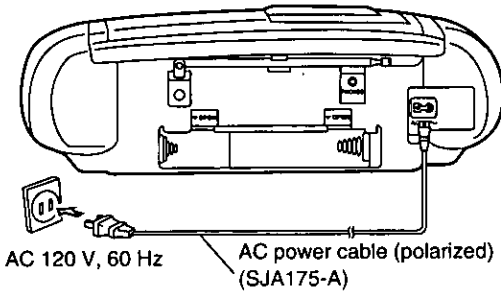

If the unit is not going to be used for a prolonged period of time when a household AC outlet is used to power it, disconnect the power cable to conserve power.

**(Only for U.S.A.)**

To order accessories call PASC Accessory Dept. 1-800-332-5368.

## Using batteries (not included)

Disconnect the power cable from the AC IN~ socket on the rear panel, and insert six "D" size (R20/LR20, not included) batteries in the order numbered below.

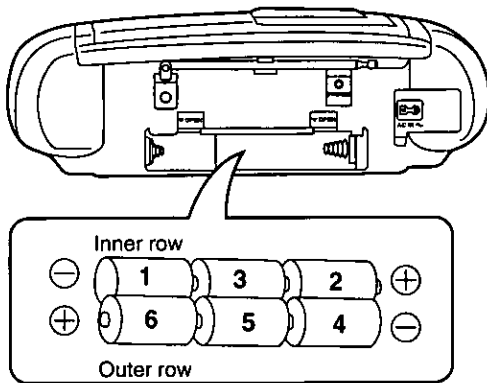

### How to remove the batteries

Insert your finger into the opening on the bottom of the unit, and push the batteries out.

### When to replace the batteries

Replace all the batteries if the sound is distorted or the unit fails to operate properly. When the batteries start to wear out, it may not be possible to play CDs properly even when there is nothing wrong with the radio and tape operations.

### Use of batteries

- Do not use rechargeable type batteries.
- Do not mix new batteries with old batteries.
- Do not mix different types of batteries (manganese with alkaline, etc.).
- Install the batteries with their (+) and (-) ends aligned properly.
- Do not recharge the batteries.
- Remove the batteries if the unit is not going to be used for a long period of time.
- Remove them if the unit is always going to be powered from a household AC outlet.
- Do not throw batteries into a fire or short-circuit, disassemble or apply heat to them.

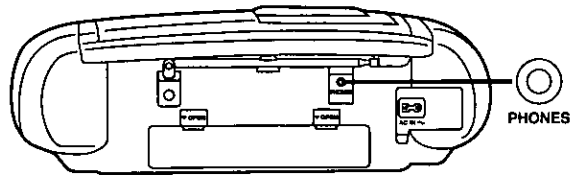
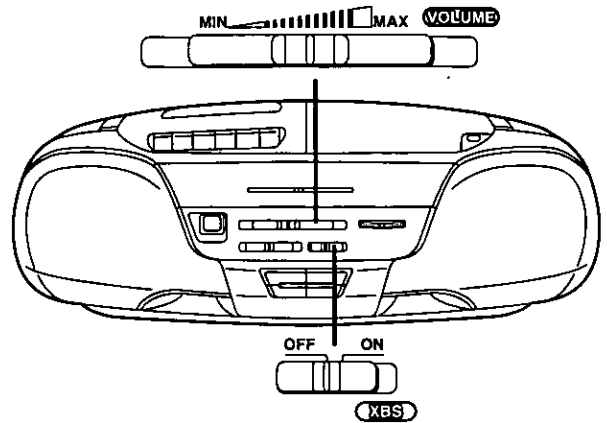

## Adjusting the volume

Slide **VOLUME** to adjust the volume to the desired level.



Slide it to "MAX" to turn up the volume. Slide it to "MIN" to turn down the volume.

## Adjusting the deep bass (XBS)

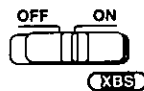

To increase the deep bass, set **XBS** to "ON".

## Listening through headphones (not included)

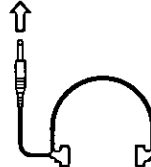

Turn down the volume and connect the headphones to the **PHONES** jack.

- Adjust the volume to the desired level.
- Plug type: 3.5 mm Stereo
  - Avoid listening for prolonged periods of time to prevent hearing damage.

# Listening to CDs

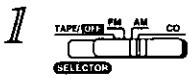
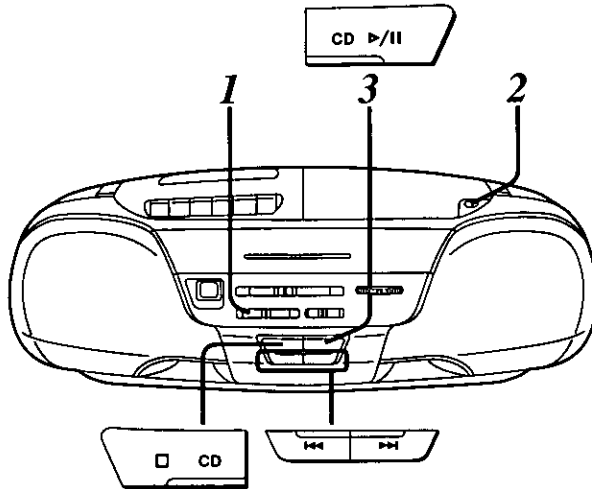

**1** Set SELECTOR to "CD".

Indicates that no disc is loaded.

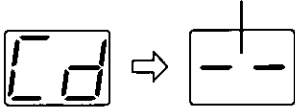

**2** Press  $\triangle$  CD, insert the CD and close the lid.

Insert the CD with its label side facing up.



Total number of tracks flashes.

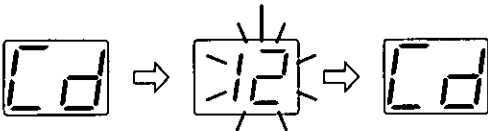

**3** Press  $\triangleright/\parallel$  to start play.

Play starts from track 1 and continues to the last track, after which it automatically stops.

After the track number now displayed flashes on and off rapidly, it will stop flashing and light up when play is commenced.

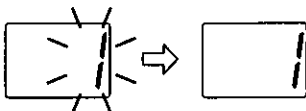

To stop play:

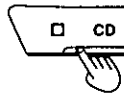

Press  $\square$ .

To stop play temporarily:

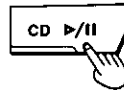

Press  $\triangleright/\parallel$ .

To resume play:  
Press  $\triangleright/\parallel$ .

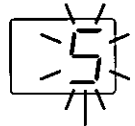

The track number display flashes on and off slowly.

Turning the power off:

Set SELECTOR to "TAPE/CD".

## Skipping to the beginning of a track

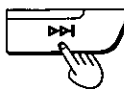

Press  $\triangleright\triangleright$  to skip to the start of the next track.

You can skip as many tracks as the number of times you press the button.

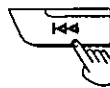

Press  $\triangleleft\triangleleft$  to skip to the start of the present track.

If you press the button again quickly, you can skip to the beginning of the previous track.

• In the stop mode, to play from the indicated track, press  $\triangleright/\parallel$ .

## Rapid forwarding and reversing (search)

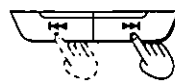

In the play or pause mode, keep pressing  $\triangleright\triangleright$  or  $\triangleleft\triangleleft$ .

Release the button at the desired position.

(Backward) (Forward)

### Notes

- Interference may affect radio or TV reception when CDs are played close to a radio or TV set. If this occurs, place the unit as far away from the set as possible.
- Do not press  $\triangle$  CD during play. CD may be scratched.

# Listening to Tapes

Only normal tapes can be used.

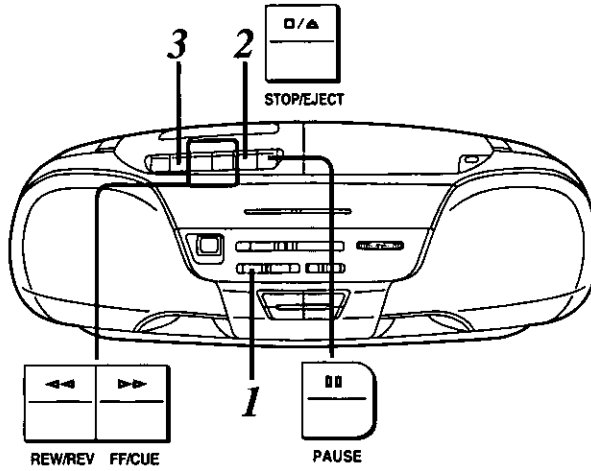

**1** Set **SELECTOR** to "TAPE/COFF".

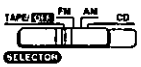

**2** Press **STOP/EJECT**, load the tape and close the cassette lid.

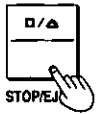

With the side to be played facing up

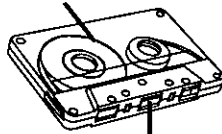

Tape facing you

**3** Press **PLAY** to start play.



Type of tape which can be played on this unit:

Normal position/TYPE I	○
High position/TYPE II	×
Metal position/TYPE IV	×

This unit will not be able to do full justice to characteristics of high position tapes and metal position tapes even if they are played back.

### Full auto-stop:

During playback, recording, fast forward or rewind when the tape reaches its end, the automatic stop system will release the operation buttons.

### To rewind or fast forward the tape

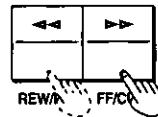

In the stop mode, press **FF/CUE** or **REW/REV**.

### To stop play:



Press **STOP/EJECT**.  
It turns the power off.

### Note

Do not press **PLAY** during rewinding or fast forwarding, as this may jam the tape. Be sure to press **STOP/EJECT** before proceeding to the next operation.

### To stop play temporarily:

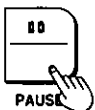

Press **PAUSE**.  
To resume play:  
Press **PAUSE** again.

### To search for a particular spot on a tape

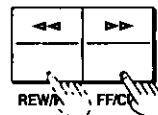

During playback, press **FF/CUE** or **REW/REV**.

Tape play is resumed when the button is released.

## Listening to the Radio

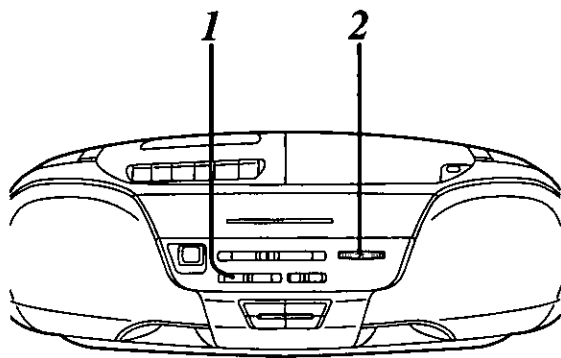

**1**  Set **SELECTOR** to "FM" or "AM".

**2**  **Tune in to the desired station using TUNING.**  
 ☺: To increase the frequency  
 ☹: To lower the frequency

**Turning the power off:**  
 Set **SELECTOR** to "TAPE/ [OFF]".

### Adjusting the antennas

**For FM reception:**  
 Pull out the telescopic antenna and adjust its length and angle for optimum reception.

**For AM reception:**  
 The sensitive ferrite core antenna inside the set will provide excellent AM reception in most areas. For optimum reception, turn the set in the direction which gives the best results since the ferrite core antenna is directional.

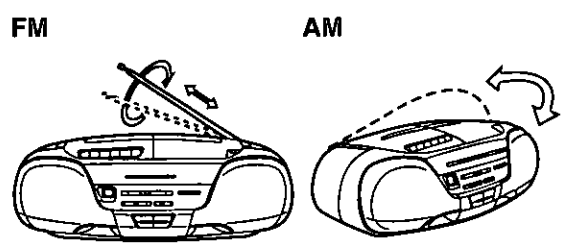



**For your reference:**  
 Radio broadcasts may be hard to receive in a moving vehicle or a building because their signals are weak. Whenever possible, use the unit by a window.

## Recording Radio Programs

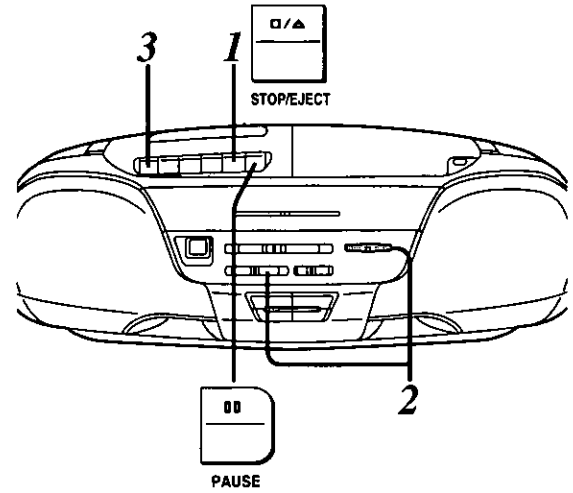
Only normal tapes can be used.



**1**  **Press □/△ STOP/EJECT and load the tape.**  
 • Load the tape with the side to be recorded facing up.  
 • Either have the leader tape wound up in advance or locate the position where recording is to begin.

**2**  **Tune in the broadcast station.** (See to the left.)  
 ↓  

**3**  **Press ○ [REC].**

**To stop the recording:**  
 **Press □/△ STOP/EJECT.**

**To stop the recording temporarily:**  
 Press || PAUSE.  
 To resume recording, press || PAUSE again.

**For your reference:**  
 • Any changes made to the volume or tone quality during recording will not affect the recording.  
 • In order to prevent trouble caused by flat batteries, it is recommended that you either supply power to the unit from the household AC outlet or replace all the batteries with new ones when you are recording something which is important to you.



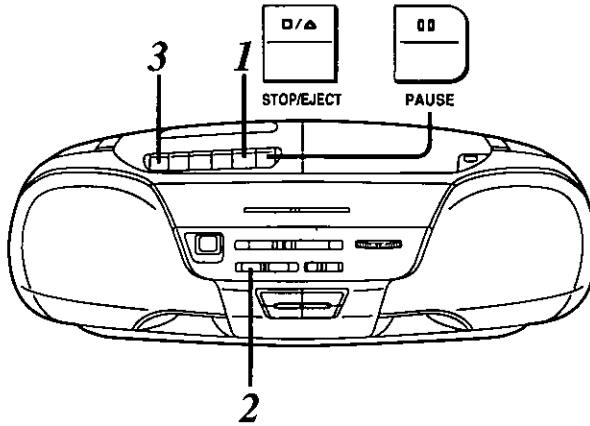

# Recording Compact Discs

Only normal tapes can be used with this unit for recording.





Preparation: Insert the CD.

- 1**  Press  STOP/EJECT and load the tape.
- Load the tape with the side to be recorded facing up.
  - Either have the leader tape wound up in advance or locate the position where recording is to begin.

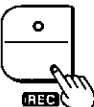
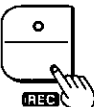
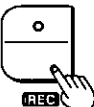
- 2**  Set SELECTOR to "CD".

- 3**  Press  (RECORD) to start recording on the tape.
- ▶ PLAY is also pressed with  (RECORD). CD play starts simultaneously. Recording stops at the end of the tape. If the tape comes to the end while a track is still being recorded, the track will be only partially recorded. To continue recording on the other side of the tape, remove the tape, turn it around, install it again, and start recording once more.

**To stop the recording:**

-  Press  STOP/EJECT. (CD does not stop.)

**To stop the recording temporarily:**

Press  PAUSE. (CD does not stop.)

To resume recording, press  PAUSE again.

**To take up the leader tape:**

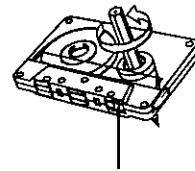





Leader tape  
(recording cannot be made)

**Type of tape which can be used for recording:**

Normal position/TYPE I	○
High position/TYPE II	×
Metal position/TYPE IV	×

The sound may not be recorded properly if high position tapes and metal tapes are used with this unit.

**Recording your favorite tracks:**

After step 2 (page 9), press  or  and display the track number before pressing  (RECORD) to start recording. When the recording is completed, press  STOP/EJECT to stop the tape.

**For your reference:**

- Any changes made to the volume or tone quality during recording will not affect the recording.
- In order to prevent trouble caused by flat batteries, it is recommended that you either supply power to the unit from the household AC outlet or replace all the batteries with new ones when you are recording something which is important to you.

# Troubleshooting Guide

Before requesting service for this unit, check the chart below for a possible cause of the problem you are experiencing. Some simple checks or a minor adjustment on your part may eliminate the problem and restore proper operation.

If you are in doubt about some of the check points, or if the remedies indicated in the chart do not solve the problem, refer to the directory of Authorized Service Centers (enclosed with this unit) to locate a convenient service center, or consult your dealer for instructions.

(In U.S.A. consult PASC Authorized Servicenters for detailed instructions or call 1-800-545-2672 for the address of an authorized factory servicenter.)

Problem	Probable cause(s)	Suggested Remedy	Page
---------	-------------------	------------------	------

Common problems			
No operation when unit is powered by dry batteries.	Is the AC power cable still connected to the unit while batteries are being used?	Disconnect the AC power cable.	5
	Are the batteries flat?	Replace them with new ones. Alternatively, use a household AC outlet as the power source.	5
	Have the batteries been installed incorrectly with their (+) and (-) polarities reversed?	Align the (+) and (-) polarities correctly.	5

While listening to CDs			
Play does not start. No display of track numbers, etc.	Has the CD been installed upside down?	Install the CD with the label side facing up.	6
	Has there been a sudden change in temperature? For instance, was the unit brought straight from a cold place into a warm location?	Condensation may have formed on the lens unit. Leave it for about an hour before attempting operation again.	2
Certain sections are not played properly.	Is the CD dirty?	Wipe it with a soft cloth.	11
	Is the CD scratched?	Replace it with a new CD.	

While listening to tapes			
Cassette is not ejected.	Are the batteries flat?	Replace them with new ones or, alternatively, use a household AC outlet as the power source and then press □/▲ STOP/EJECT after pressing ► PLAY.	5
No recording.	Have the tape's accidental erasure prevention tabs been broken out?	Cover the holes with adhesive tape.	11
High level of noise; poor sound quality.	Are the heads dirty?	Clean them.	12

While listening to the radio			
High level of noise; stations cannot be tuned in well.	Has the antenna been adjusted properly?	Try changing its direction.	8
Noise heard during AM reception.	Are you using a remote controller near the unit?	Use the remote controller at a distance.	
	Are you operating the unit and a TV set at the same time?	Place the unit at a distance from the TV. Alternatively, turn off the TV's power.	

## Concerning Compact Discs

Only compact discs having this mark can be used with this unit.

However, continued use of irregular shape CDs (heart-shape, octagonal, etc.) can damage the unit.

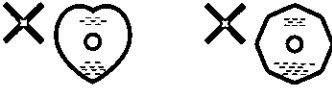

### □ To hold the disc

Hold the disc by the edges so the surface is not soiled with fingerprints. Fingerprints, dirt and scratches can cause skipping and distortion.

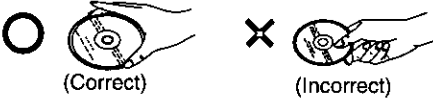

### □ To store a disc in its case

Insert the disc with label facing upwards and press downward at the center.

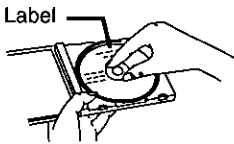

### □ If the surface is soiled

Wipe gently with a soft, damp (water only) cloth.

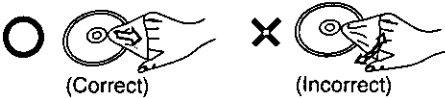

### □ If the disc is brought from a cold to a warm environment, moisture may form on the disc

Wipe off with a soft, dry, lint-free cloth before using the disc.

### Improper disc storage:

You can damage discs if you store them in the following places;

- Areas exposed to direct sunlight
- Humid or dusty areas
- Areas directly exposed to a heat outlet or heating appliance

### Handling precautions:

- Do not write on the disc with a ball-point pen or other writing utensils.
- Do not use record cleaning sprays, benzene, thinner or alcohol to clean the disc.
- Do not attach stickers or pieces of paper. (When stickers have been adhered, the glue or other substances may have oozed out. Since this may cause malfunctioning, remove all stickers and paper before use.)

## Concerning Cassette Tapes

### □ Selection of cassette tapes

#### Cassette tapes exceeding 100 minutes:

These tapes are handy for their long playback and recording time but be careful about repeatedly stopping and starting, rewinding and fast forwarding these tapes in short intervals as they are thin, tend to stretch and may become entangled in the deck mechanism.

#### Endless tapes:

Failure to operate these tapes correctly may cause the tape to wind around the revolving parts.

### □ If the tape loosens, take up the slack

Tape slack may cause the tape to break.



### □ To prevent erasure of recorded sounds

Remove the erase-prevention tabs with a screwdriver or a similar object.

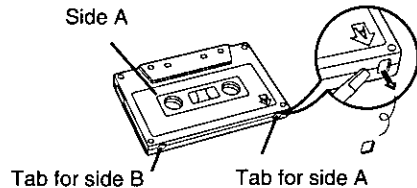

To re-record on a protected cassette, cover the slot with adhesive tape.

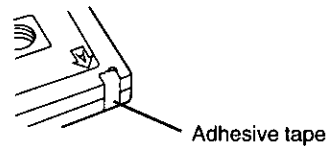

### Improper tape storage:

You can damage tapes if you store them in the following places;

- In high temperature [35°C (95°F) or higher] or high humidity (80% or higher) areas
- In a strong magnetic field (near a speaker, on top of a TV, etc.)

This can erase a recording.

- Areas exposed to direct sunlight

### To erase all the sound on a tape:

1. Load the tape with the side whose recording is to be erased facing up.
2. Set SELECTOR to TAPE/ [OFF].
3. Press O [REC].

## Maintenance

### □ Maintenance of external surfaces

Clean it with a cloth, dampened in a mild solution of soap and water.

Do not clean the cabinet with benzine or thinner.

Avoid excessive moisture.

Avoid spray aerosol type cleaner. Some cleaners contain corrosive chemicals that may cause internal damage and cabinet deformation.

### □ Tape head care

To assure sound quality for recording and playback, be sure to clean the tape heads after approximately every 10 hours of use.

1. Open the cassette lid by pressing **□/△ STOP/EJECT**.
2. Clean the tape heads, pinch rollers and the capstan shafts with a cotton swab (or a soft, lint-free cloth) slightly moistened with isopropyl alcohol.  
Do not use any solution other than alcohol for head cleaning.

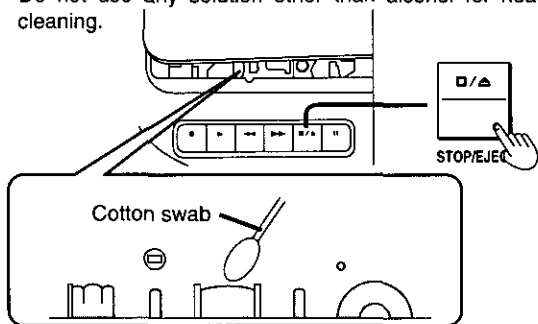

### □ Lens care

Open the disc holder and clean the lens with a blower (not included). If the lens is extremely dirty, clean it with a cotton swab.

Recommended product: Lens cleaner kit (SZZP1038C)

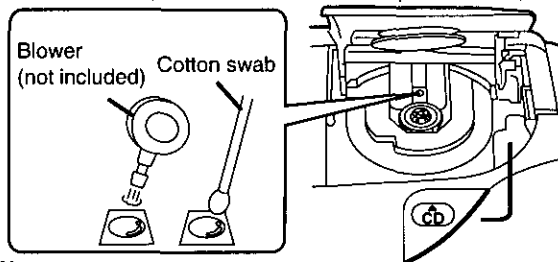

User memo:

DATE OF PURCHASE \_\_\_\_\_  
DEALER NAME \_\_\_\_\_  
DEALER ADDRESS \_\_\_\_\_  
TELEPHONE NUMBER \_\_\_\_\_

## Technical Specifications

### □ Radio

Frequency range

FM

88-108 MHz

AM

525-1710 kHz

### □ CD player

Sampling frequency

44.1 kHz

Decoding

16 bit linear

Beam source

Semiconductor laser  
(wavelength 780 nm)

No. of channels

2 channel, stereo

Wow and flutter

Below measurable limit

D/A converter

MASH (1 bit DAC)

### □ Tape recorder

Track system

4 track, 2 channel, stereo

Recording system

AC bias

Erasing system

Multi pole magnet

Monitor system

Variable sound monitor

Frequency range (Normal)

30-12000 Hz

### □ General

Speakers

10 cm (4") 4Ω×2

Output jack

Headphones; 3.5 mm 32Ω

Power requirement

AC

120 V, 60 Hz,

Power consumption; 14 W

Battery

9 V [Six R20/LR20 (D, UM-1) batteries]

Do not use rechargeable type batteries.

Dimensions (W×H×D)

470×158×254 mm

(18½"×6¼"×10")

Weight

2.9 kg (6 lb. 6 oz.) without batteries

### Note:

Specifications are subject to change without notice.

Weight and dimensions are approximate.

MASH is a trademark of NTT.

## Product Service

Do not attempt to remove the cover(s) or repair the unit yourself. Refer servicing to qualified personnel only.

### Product information

For product service, product information or assistance with product operation, refer to the servicenter directory.

**Panasonic Consumer Electronics Company, Division of Matsushita Electric Corporation of America**  
One Panasonic Way Secaucus, New Jersey 07094

**Panasonic Sales Company, Division of Matsushita Electric of Puerto Rico, Inc. ("PSC")**  
Ave. 65 de Infantería, Km. 9.5  
San Gabriel Industrial Park, Carolina, Puerto Rico 00985

**Panasonic Canada Inc.**  
5770 Ambler Drive,  
Mississauga, Ontario  
L4W 2T3

RQT3644-P  
F0996L2027 (D)